

Technical Data Coin-type Manganese Dioxide Lithium Battery

Type: CR1220

2020/04/21

TOSHIBA LIFESTYLE PRODUCTS & SERVICES CORPORATION

Ratings

Battery system		Coin-type Manganese Dioxide Lithium Battery
Item		
Battery type		CR1220
Nominal Voltage		3.0V
Standard Capacity [Condition]		40 mAh [on continuous discharge under 62kΩ load to 2.0V end-point at 20deg.C]
Terminals	Cap Terminals	SUS + Ni plate
	Base Terminals	SUS + Ni plate
Outer dimensions	Diameter	φ12.5(0/-0.3)mm
	Overall height	2.0(0/-0.2)mm
Usable temperature range		-20 ~ 65deg.C
Storage temperature range		

This is only for reference.(not guaranteed.) This information contained herein may be changed without prior notice.
Proprietary materials of TOSHIBA LIFESTYLE PRODUCTS & SERVICES CORPORATION

CR1220 Discharge Characteristics

Test condition : cotinuous discharge, Initial, 20deg.C

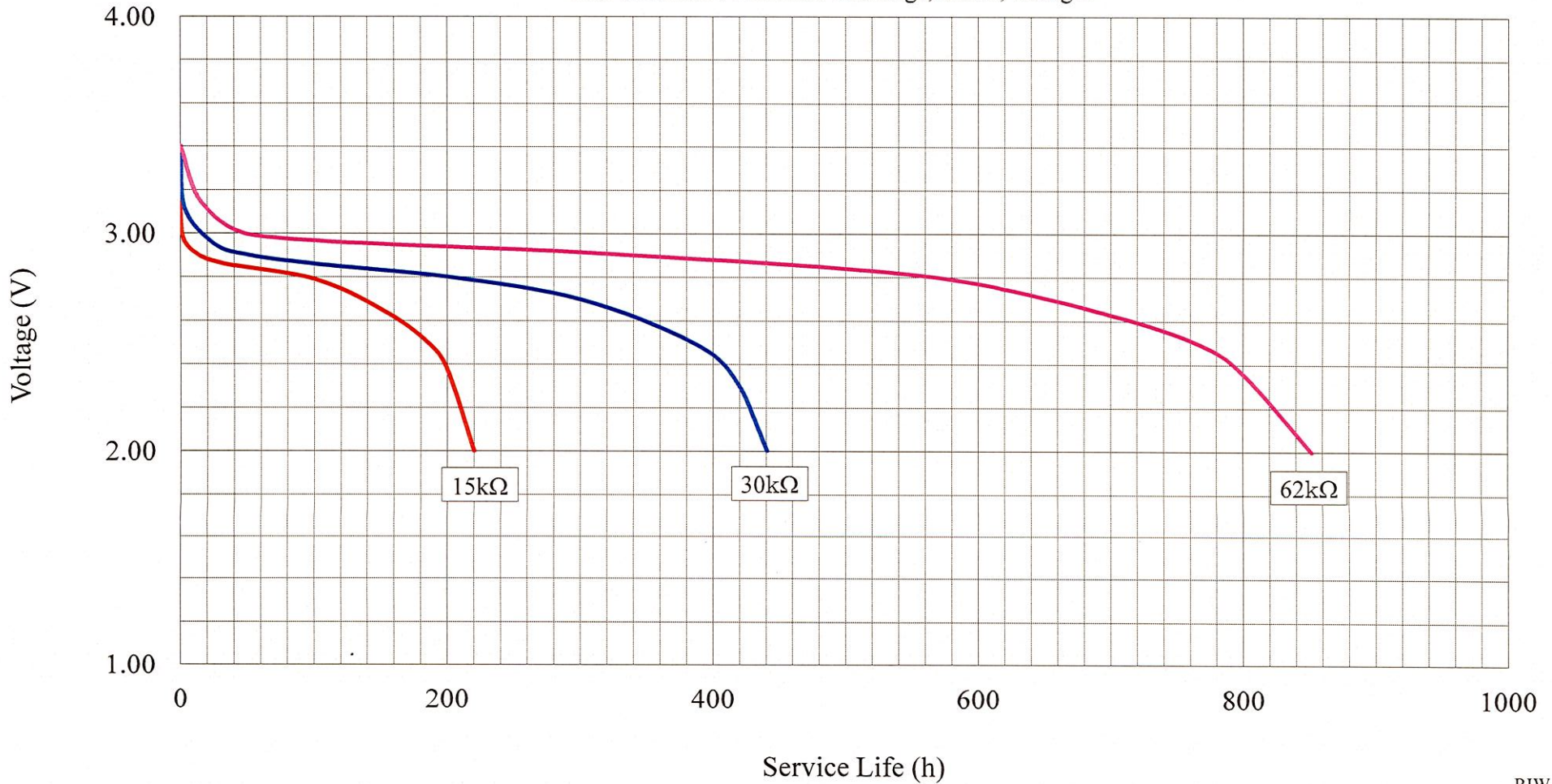

RIW-K

This is only for reference. (not guaranteed.) The information contained herein may be changed without prior notice.

Proprietary materials of TOSHIBA LIFESTYLE PRODUCTS & SERVICES CORPORATION

CR1220 Discharge Characteristics

Test condition: 62kΩ continuous discharge, Initial

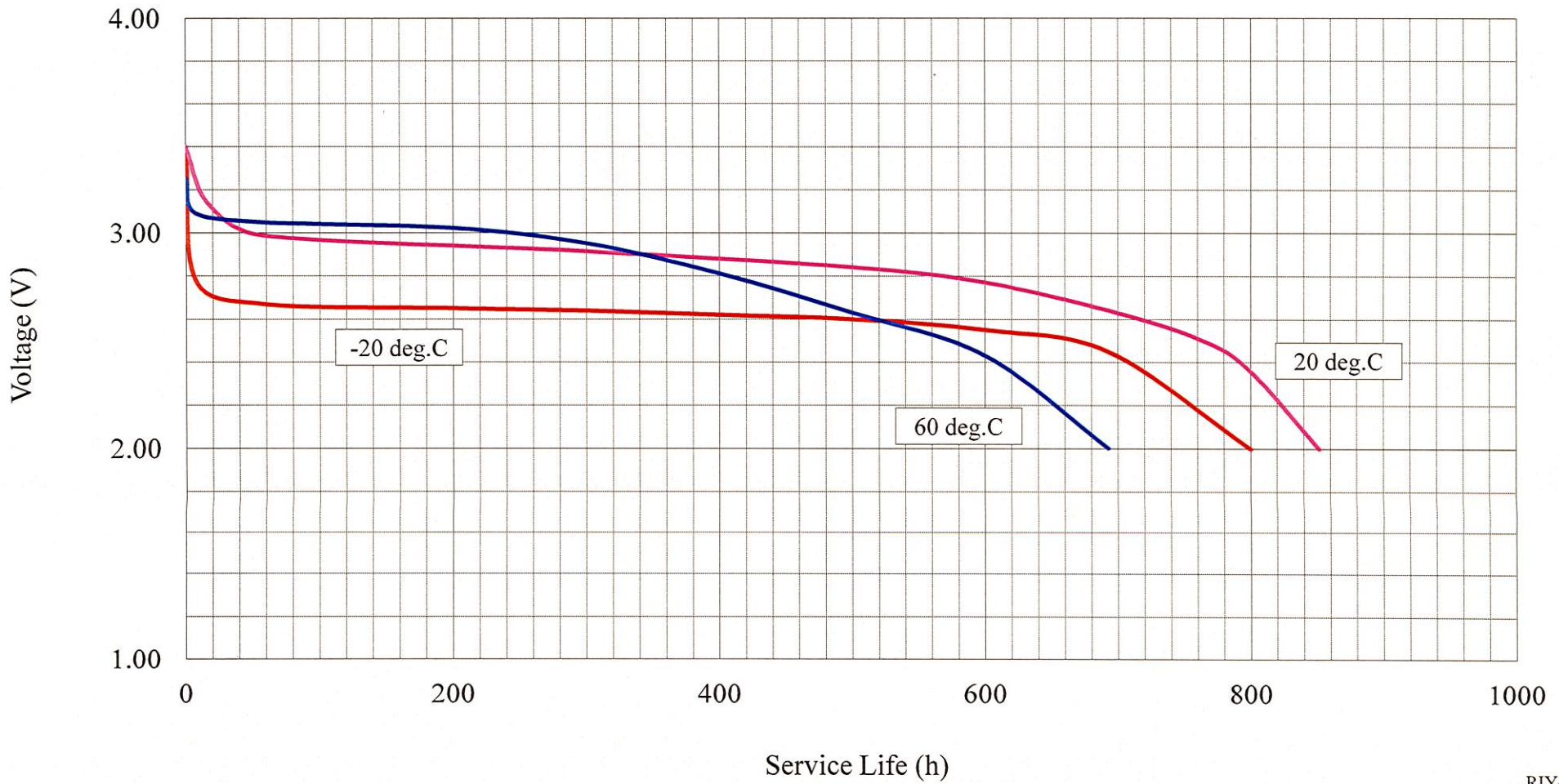

RIY-K

This is only for reference. (not guaranteed.) The information contained herein may be changed without prior notice.

Proprietary materials of TOSHIBA LIFESTYLE PRODUCTS & SERVICES CORPORATION

CR1220 Load Resistance vs Capacity

Test condition : Initial, 20 deg.C

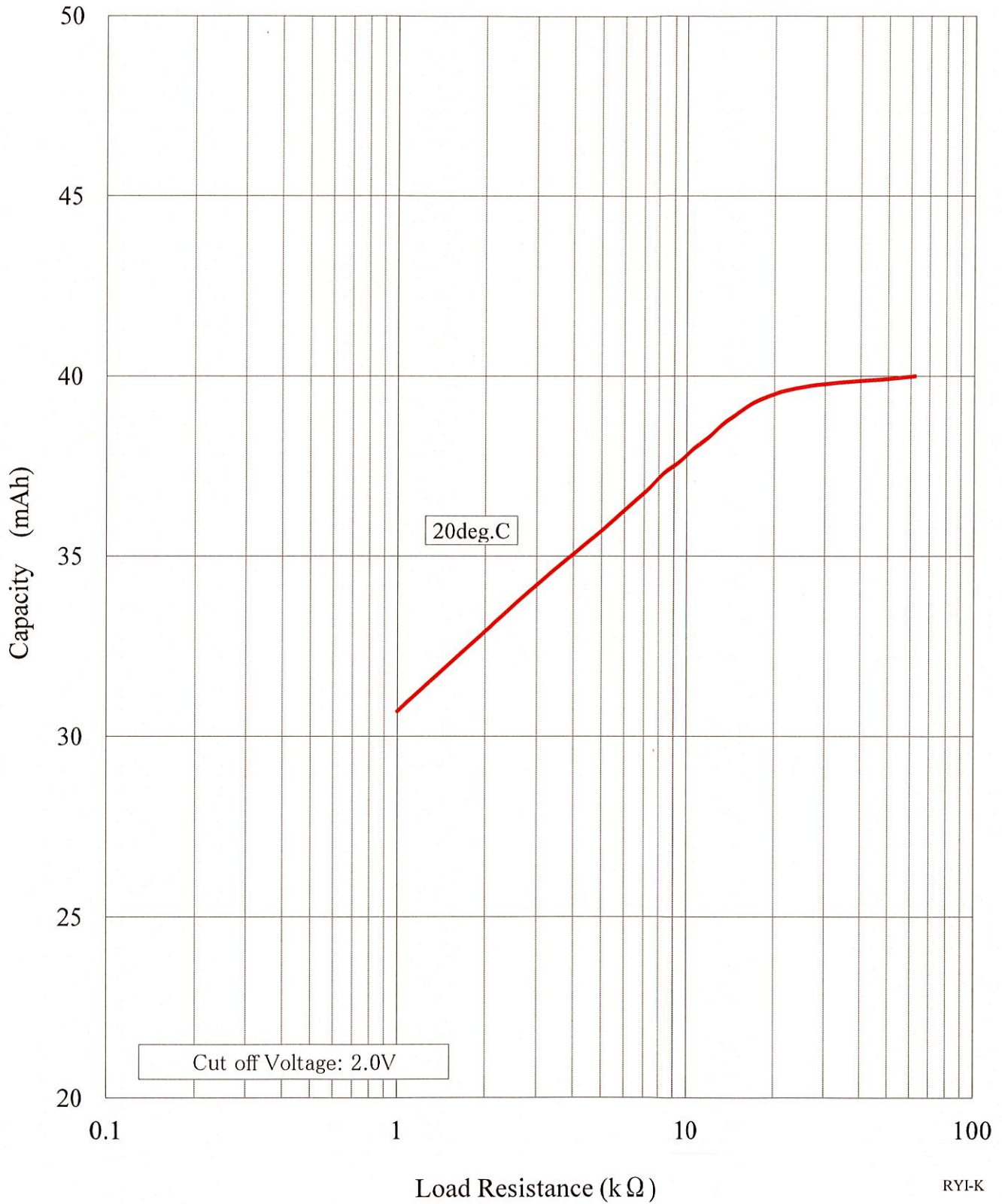

This is only for reference. (not guaranteed.) The information contained herein may be changed without prior notice.

Proprietary materials of TOSHIBA LIFESTYLE PRODUCTS & SERVICES CORPORATION

CR1220 Leakage Performance

		Test items	Electrolyte Leakage (%)			
		Storage period	20days	40days	60days	90days
Test condition						
Storage at high temperature and high humidity	45deg.C-70%RH		0	0	0	0
	60deg.C-90%RH		0	0	-	-
Temperature cycle	Temperature: -10deg.C ⇔ 60deg.C (4h/Cycle, 6cycle/day)		0	-	-	-

This is only for reference.(not guaranteed.) This information contained herein may be changed without prior notice.

Proprietary materials of TOSHIBA LIFESTYLE PRODUCTS & SERVICES CORPORATION

CR1220 Safety Evaluation Test

	n	Conditions	Requirements
Heat test	5	Cells are kept stored for 24hrs. Temperature: 80+/-2deg.C Humidity: 70%RH or less.	Open-circuit voltage is to be kept same as initial value. No abnormal appearance and no substandard dimensions are to be observed.
Vibration test	5	Amplitude: 1.0mm Frequency: 10 to 55 to 10Hz Sweep: 1minute Period: 2h per each direction of X and Y axes, 4h in total	Open-circuit voltage is to be kept same as initial value. No abnormal appearance and no substandard dimensions are to be observed.
Drop test	5	Number of drops: 10 times Height: 75cm Floor: Concrete Direction: Free	Open-circuit voltage is to be kept same as initial value. No abnormal appearance and no substandard dimensions are to be observed.
Weighing test	5	Weight of 19.8N(2kgf) is laid for 1 hour and 9.8N(1kgf) for 24 hours respectively on all over negative side of cells.	Open-circuit voltage is to be kept same as initial value. No abnormal appearance and no substandard dimensions are to be observed.
Short-circuit test	5	Cells are Short-circuited for 48 hours.	No burst, No fire

CR1220 Outline Drawing

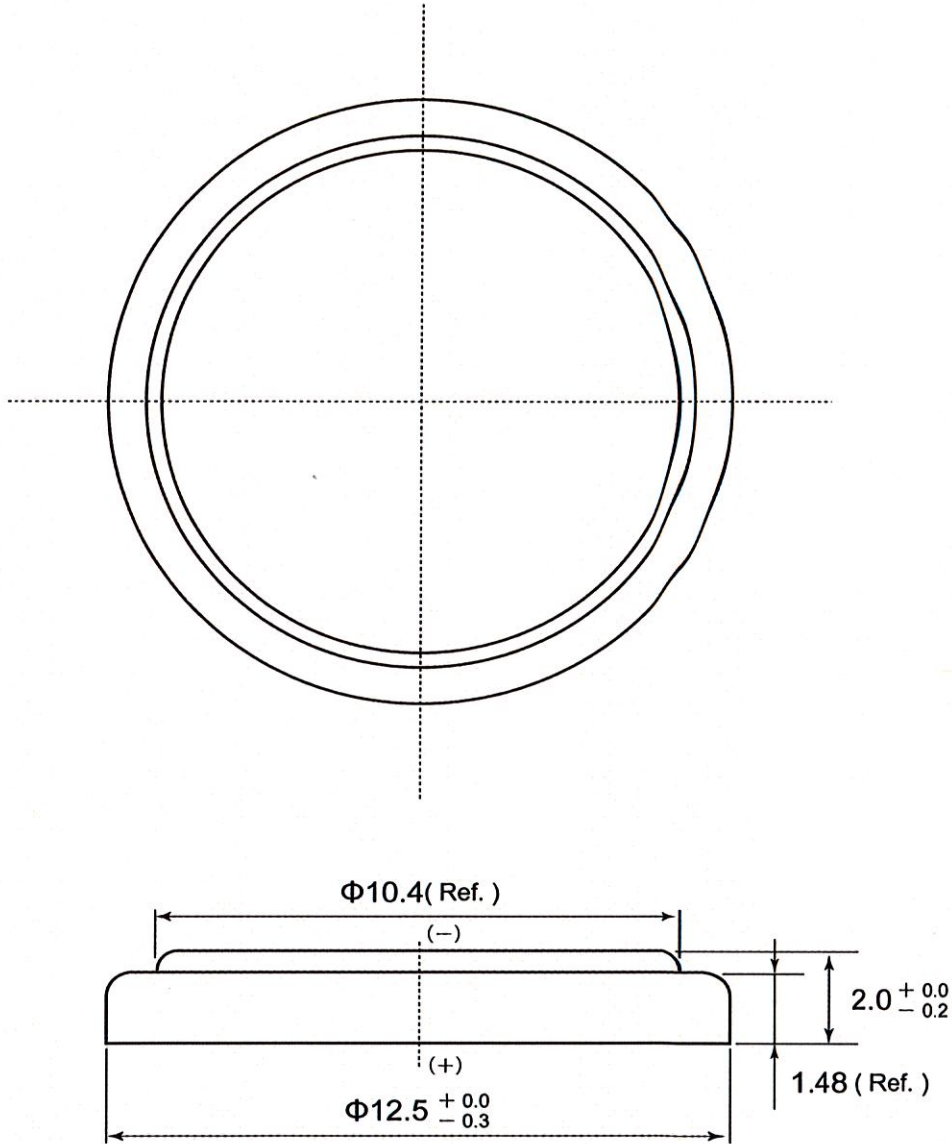

Unit: mm

This is only for reference.(not guaranteed.) This information contained herein may be changed without prior notice.

Proprietary materials of TOSHIBA LIFESTYLE PRODUCTS & SERVICES CORPORATION